

# Hazel B. Ladnier – Marriage With Tommy Ladnier

Bo Lindström

## The Mathews family

As can be seen from *Traveling Blues*, all we knew about Tommy Ladnier's wife was that she lived in Michigan after Tommy's death and that the 1930 Chicago census comprised one Daisy Ladiner (sic). The Sidney Bechet recollections give some insight in her character, but no real information on her family data. There was also a 1923 photo showing the Ladnier and Baby Dodds couples.

Later on, information from the Jackson, Michigan, city directories have spread some more light on Tommy's wife, revealing that her real name was Hazel B. Ladnier. A Chicago marriage license Index also showed that her maiden name was Mathews and that Tommy married her on February 1<sup>st</sup>, 1920.<sup>1</sup> But there still were many more unanswered questions. However, with the recent release of the 1940 census, a much clearer picture of this woman and her family has emerged.

Hazel's father was Thomas E. Mathews, born in January 1870, either in Michigan or in Kentucky.<sup>2</sup> Nothing is known about his parents or about his childhood. The first official document found is the 1900 Jackson, MI, census of January 7, 1900, showing him as married to Lena N. Mathews.<sup>3</sup> Thomas' profession was stated as "Machinist". They were married in 1897 and had a son, Harrison W, born August 1898 in Michigan. At that time they lived at 155 E. Cooper St. in Jackson. Lena N. Mathews was born in January 1880 in either Michigan or Missouri.<sup>4</sup> Just like for Thomas E, her parents are unknown but stemming from Kentucky.

## The Thomas family

Sometime before 1920, Lena N. had left Thomas Mathews and moved to Chicago, living as roomer on 3414 Prairie Avenue. With her were also her new husband Ray Thomas and Hazel B. Thomas.<sup>5</sup> Ray and Lena were married; Lena and Thomas had probably divorced as Thomas E. Mathews stayed in Jackson, living at 360 Porter Street, located in the Northern outskirts of the city. Actually, he stayed at this address until at least 1946 even though the street was renumbered as 224 E. Porter Street around 1922.<sup>6</sup>

Unfortunately, it is not known for how long time Lena and Ray had been married in 1920. Lena was 39 years old, indicating a birth in 1880. Roy was much younger, born in Pennsylvania in 1895. Nothing is known about his parents but they were born in Maryland. He was working at a "Theatre" and Lena was working at home as "Musical teacher."<sup>7</sup> Hazel's was 17 years old, indicating a birth in 1902. The fact that Hazel was shown as Hazel Thomas seems to have been under debate, since the enumerator evidently has written another name at first and this could possibly have been Mathews. However, there is also another option. In 1940, Hazel declared that she had been married twice and that her first marriage took place when she was 14 years old.<sup>8</sup> This would indicate that she first married around 1916. Who this husband was, if they divorced or if he

---

<sup>1</sup> Cook County Marriage Index 1914-1942, Page 6587. Actually, the spelling in the Index is Matthews. In this paper, I will use the most common spelling Mathews even though some documents use the name with two t:s.

<sup>2</sup> The State varies in different official documents found.

<sup>3</sup> Census 1900, E.D. 19 Sheet 10B, Jackson City, Jackson, Michigan.

<sup>4</sup> The State reported varies in different official documents found.

<sup>5</sup> Census 1920, E.D. 87, Sheet 8B, Chicago, Cook County, Illinois.

<sup>6</sup> Polk's Jackson CD 1917-1922, 1935, 1937, 1938, 1941, and 1946. Also in the 1940 census, E.D. 38-50, Sheet 1A, Jackson City, Jackson, Michigan.

<sup>7</sup> The exact job Ray Thomas had at the theatre has not been possible to decipher from the census form.

<sup>8</sup> Census 1940, E.D. 38-30, Sheet 3B, Jackson City, Jackson, Michigan.

had died is not known. In 1920, she was reported as single but who the informant was is unknown; it was perhaps the house head Agnes Young, who naturally was not too well informed about her resident's personal lives.

## Marriage

Just a few days after the 1920 census, on February 1<sup>st</sup>, Hazel married Thomas J Ladnier and was then recorded with her maiden name Hazel B. Mathews.<sup>9</sup> It is of course impossible to know how Tommy and Hazel met but one speculation would be that Tommy first had met Ray Thomas at the theatre. It seems Tommy made friends very easily and his contact net was vast. However, if the acquaintance with Ray was one possibility, yet another option would be that Tommy took music lessons from Lena at their home. This is very possible since we know that Tommy was eager to learn more about music – and many other subjects – and also studied by correspondence during the European tour.



**Hazel B. and Tommy Ladnier 1923**

As *Traveling Blues* shows, Tommy and Hazel seems to already have drifted apart around the time of his mothers death in 1923, and his subsequent affair with Lovie Austin didn't help. Nor did his long European journey 1925 to 1927. Upon returning to US in 1927, he stayed in New York.

Hazel moved back to Jackson during this time and she stayed with her biological father Thomas E. Mathews at 224 E. Porter Street.<sup>10</sup> Nevertheless, she then moved back to Chicago in 1930, living as "Daisy" Ladiner (sic), rooming at 4632 Prairie Avenue.<sup>11</sup> The apartment house head was William Monerie, and his wife Olivia worked as "Waitress at Café" just as "Daisy". Maybe Daisy was the name she was known under at the café and the census informant, probably one of the Moneries, didn't know all her personal data.

---

<sup>9</sup> Cook County Marriage Index 1914-1942, p. 6587.

<sup>10</sup> Polk's Jackson City Directory 1929 p. 312.

<sup>11</sup> Census 1930, Chicago, Cook County, E.D. 16-145, Sheet 6A. Next door, at 4636 Prairie Avenue, lived trumpeter Robert "Bob" Schoffner – who had succeed Tommy Ladnier in Lovie Austin's Blues Serenaders – and his wife Pearl, and also Thomas Pinkney – who probably is not identical to pianist Lloyd Pinkney who at this time in 1930 was playing with Noble Sissle and Tommy Ladnier in Paris, France – and his wife Thelma.

PLACE OF BIRTH		NAME		RELATION		HOME DATA		PERSONAL DESCRIPTION		EDUCATION		PLACE OF BIRTH		MOTHER TONGUE OR BIRTH LANGUAGE OF FOREIGN BORN		CITIZENSHIP, ETC.		OCCUPATION AND INDUSTRY		EMPLOYMENT	
1	2	3	4	5	6	7	8	9	10	11	12	13	14	15	16	17	18	19	20	21	22
1	26	121	Hath, Maryella	Wife of				F	1870	12	12	Alabama	Alabama	Alabama							
2			Wright, Thomas	Husband				F	1870	12	12	Alabama	Alabama	Alabama							
3			Wright, Thomas	Son of				F	1870	12	12	Alabama	Alabama	Alabama							
4			Wright, Thomas	Son of				F	1870	12	12	Alabama	Alabama	Alabama							
5			Wright, Thomas	Son of				F	1870	12	12	Alabama	Alabama	Alabama							
6			Wright, Thomas	Son of				F	1870	12	12	Alabama	Alabama	Alabama							
7			Wright, Thomas	Son of				F	1870	12	12	Alabama	Alabama	Alabama							
8			Wright, Thomas	Son of				F	1870	12	12	Alabama	Alabama	Alabama							
9			Wright, Thomas	Son of				F	1870	12	12	Alabama	Alabama	Alabama							
10			Wright, Thomas	Son of				F	1870	12	12	Alabama	Alabama	Alabama							
11			Wright, Thomas	Son of				F	1870	12	12	Alabama	Alabama	Alabama							
12			Wright, Thomas	Son of				F	1870	12	12	Alabama	Alabama	Alabama							
13			Wright, Thomas	Son of				F	1870	12	12	Alabama	Alabama	Alabama							
14			Wright, Thomas	Son of				F	1870	12	12	Alabama	Alabama	Alabama							
15			Wright, Thomas	Son of				F	1870	12	12	Alabama	Alabama	Alabama							

### Daisy Ladiner census 1930

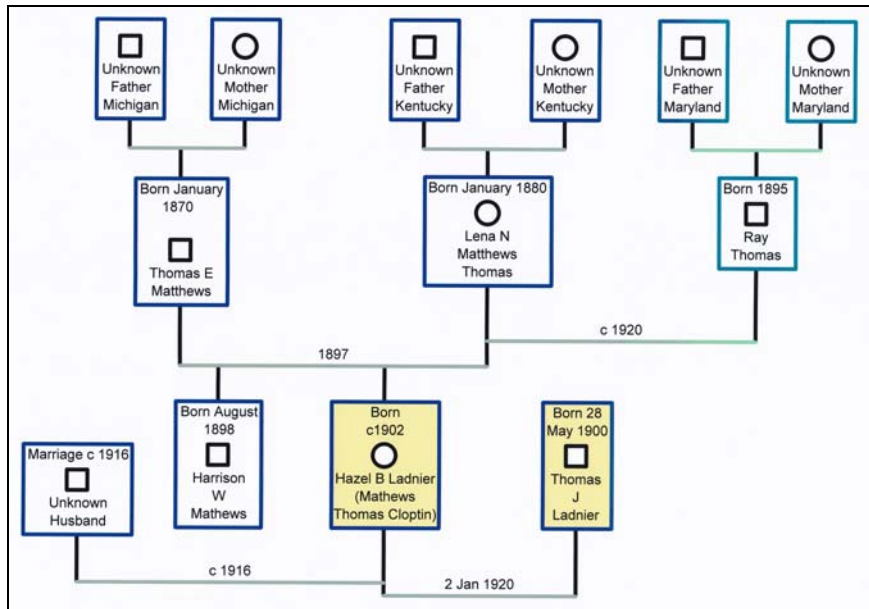

### The Hazel B. Ladnier pedigree

#### Life in Jackson

From the Sidney Bechet recollections, we know that Hazel lived with Tommy in New York in the early '30s. She had very strong views on naming the New Orleans Feetwarmers and she pushed Tommy to claim this band as the leader. Tommy, caught between the very strong wills of both Hazel and Sidney, just kept out of this dispute, which of course didn't help his already strained relationship to Hazel. Sidney Bechet describes his clashes with Hazel in his autobiography. Bechet places this as in 1938, but other, perhaps more reliable, sources indicate that this happened already when the New Orleans Feetwarmers were formed in 1932.<sup>12</sup>

*I tried one time to get a real New Orleans band together, that was in 1938. It was with Tommy Ladnier. I wanted him to come with me and start a band where we could play how we wanted to play, composing our own numbers and all. I wanted to play things the way they really had been played back in New Orleans, not doing a whole lot of unnecessary numbers that's like putting on a switch for a lamp when there's already plenty daylight. It was my idea that we'd just play how we felt.*

*Tommy, he was all enthused; but right away his wife, she began to get after him. She tells him, why don't he get a band of his own? 'This way Sidney, he'll get all the credit.' She says, 'You ought to watch out for yourself. You'll never get anywhere on that.'*

*Well, it's all the things a wife can say to her husband. I had nothing to say against her; she was doing how a wife does, it was her right. But she didn't really understand about the music. And another thing – she couldn't see the present. She was seeing what we could be, how we could go over. She was having pictures of one of those 'it's going to be wonderful, it can't come soon enough, but look at it now' things. She was seeing what a woman wants to*

<sup>12</sup> Bechet, Sidney, Treat it Gentle. An Autobiography, Da Capo Press, 1978.

*see, all how she would have a lot of fine things. Only her trouble was she saw them too soon; they weren't there yet.*

In the end, Hazel moved back to Jackson. Perhaps she at first again roomed with her father at 224 E. Porter or else hired a room somewhere else. Unfortunately, the Jackson City Directories of 1930 to 1935 are unavailable, but she shows up in 1936 at her own house at 315 E. Franklin Street. Strangely enough, she now appears as householder under the name of Hazel B. Cloptin.<sup>13</sup>

Cloptin is a very unusual name and the African-American Cloptins are located mainly in Alabama.<sup>14</sup> We can only speculate on the causes for this change of name, but no rational cause can be found. Maybe she lived with one Cloptin, but this is rather improbable since this name is so rare and there are no occurrences in any Northern state at that time. From her own statements in 1940, she only married twice, so the name change was not caused by a legal marriage. And already the next year, the registered householder at 315 Franklin Street is Hazel B. Ladnier.<sup>15</sup> Hazel remains householder at this address in 1938 and 1939. In 1940, she had moved to the next block and now lived as householder at 209 East Wesley Street, while the new householder of her previous house at 315 E. Franklin was one Janice Simpson.<sup>16</sup>

Hazel's mother Lena cannot be found in the 1930 Census. There are many Lena Thomas but it is impossible to know who is the right person. Nor are there any traces of her in Jackson in the years 1936 -1939.

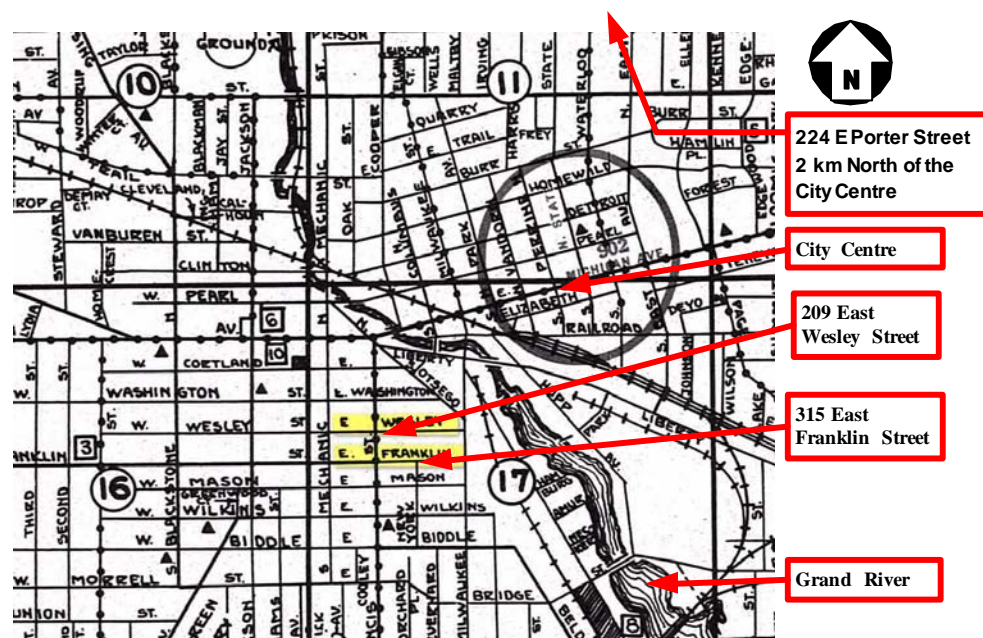

**Jackson centre 1937**

### **The 1940 census**

The 1940 census is by far the most extensive enumeration performed in the U.S. so far published.<sup>17</sup> Not only are there more questions asked than ever before; for two of the 50 citizens displayed on each sheet, supplementary questions are also given. In the enumeration for 209 East Wesley, Hazel Ladnier, head and widow, is enumerated. In the 1940 enumeration, the informants

<sup>13</sup> Polk's Jackson City Directory 1936, pp. 132 and 478 (Street Index).

<sup>14</sup> There were only 8 African-Americans and 2 White Cloptins in the whole 1900-1930 census records enumerated, mainly in Alabama and Arkansas.

<sup>15</sup> Polk's Jackson City Directory 1937, p 230 and 452 (Street Index). A householder doesn't necessarily own the house but Hazel B. states that she is the owner of the house in the 1940 census.

<sup>16</sup> Polk's Jackson City Directory 1940, p 437 (Street Index).

<sup>17</sup> U.S. law requires a 72 year span for publication of these documents.



are showed and we therefore know that Hazel herself provided the information. With her lived also her mother, Lena Thomas, roomer, and stated as single although the real designation should have been “Divorced”. What is especially interesting is that Hazel happened to be one of the persons given the supplementary questions.

Hazel owned her house and the estimated value is \$2000.<sup>18</sup> Other persons living in the house were, besides Lena Thomas: Lena McLaurey (Female, Roomer, 23), Ethel Compere(?) (Female, Roomer, 34), and Arthur Logan (Male, Roomer, 24). For all living in this house, i.e. also Hazel B. and Lena, the occupation stated is “Entertainer Own home”. In the Supplementary questions given to Hazel, the occupation is clarified as “Entertainer Sporting house”. By definition, a sporting house is an euphemistic word for brothel, but can also mean a place frequented by gamblers or other sportsmen. We can surely omit the second meaning and we end up with the fact that Hazel B. in 1940 probably was a Madam. Hazel was the “Employer” while the others, including Lena, were designed as “Private workers”. The role Lena played here is not clear. However, in 1942, Lena has bought a newly built house of her own, at 213 East Wesley Street, which was the house next to Hazel’s, and she is now again “musical teacher”.<sup>19</sup> In the Professional City Directory section, she is stated as teaching piano. At the same time, she is listed as “Widow of Ray”.

### The 1940 census for Hazel Ladnier (condensed)

The girls McLaure and Compere perhaps were the prostitutes and probably Logan was “service employee” or perhaps a gigolo. Still, all this is rather strange, considering that this house was a one family house in a family neighbourhood. However, in 1930, the whole area was inhabited by White families only, but by 1940, it had become a racially mixed area, indicating the start of a slow deterioration into a slum. The whole block is today completely destroyed and used as a parking place for a huge commerce complex across the street.

Hazel’s earlier house at 315 E. Franklin, was in 1940 owned by Janice Simpson, born in Louisiana, probably aged 42.<sup>20</sup> Her occupation was exactly the same as Hazel’s and she also had three roomers; two girls aged 19 and 21 and one man aged 50. All are enumerated as “Entertainers at home”. None of them have, just as in the case of Hazel’s house, stated any income. With the

<sup>18</sup> The average estimated value of the houses in this neighbourhood in 1940 (based on 113 houses) was circa \$600 but the variation was very high, from \$3 to \$5,000, indicating that new-built houses were located among shack-like dwellings. Often houses valued high were next to such shacks so there was no clear “high standard” area. Roughly, the area was populated evenly by African-Americans and Whites.

<sup>19</sup> Polk’s Jackson City Directory 1942; p. 343, p. 466 (Street Index), and p. 549. There was no house built on 211 East Wesley Street at the time of the 1940 census.

<sup>20</sup> The first digit is blurred and difficult to read.

similarity to the situation in Hazel's house and the persons present, this could hardly be just a coincidence and it gives the impression of a systematic business, perhaps run by someone else. This area of course was not a "red light district" and checking all other houses in the neighbourhood reveals a lower middle class community with just living quarters and no other business like these.

Hazel also gives some information about her education. She has a 4 year High School education as has Lena, so these women were well educated; in fact among the most well educated persons in the area. For some reason, she doesn't give any answer to her income, nor does Janice Simpson. Although she appears to be well off in 1940, this will evidently change in the coming years. One indication already seen in 1940 is the estimated value of her house is \$2,000, while the house she left at 315 Franklin is valued at 2,600. So her economic situation in 1940 could already have been strained and this explains why Mezz Mezzrow, after Tommy's death in June 1939, wrote:<sup>21</sup>

*On June 5<sup>th</sup> we buried Tommy in the Frederick Douglass Memorial Cemetery out on Staten Island, and I still owe the undertaker forty bucks which he refused to take because he thought some of the big-time orchestra leaders should have come through for Tommy. The police located a wife of Tommy's in Jackson, Michigan, and she wired me to call her collect. I did. The first and only thing she asked about Tommy was what had happened to his estate. "Tommy's estate is at the police station," I told her. "It consists of one pair of soiled socks, one torn shirt, and a set of raggedy underwear." That was the list of Tommy's worldly goods. He was one of the more prosperous New Orleans musicians.*

The 1940 census includes the question where the person lived in 1935. The options here can be "Same place", meaning Jackson, or "Same house", meaning 209 E. Wesley, or just blank. Hazel here answers "Same house", which we know is false, but she perhaps thought that the relocation from 315 E. Franklin was unimportant. Moreover, for Lena she gives the same answer so this doesn't give us any reliable information on Lena's whereabouts before 1940 – it could mean that she had been living with Hazel for years but it could also mean that she had lived somewhere else in Jackson.

Finally, Hazel answered one important question we have always wondered about: she had no children at all.

### **And then?**

In 1943, there were some dramatic changes.<sup>22</sup> Hazel was now a *roomer* at 209 E. Wesley and Lena was the householder. However, the street index shows one Mylo Dixon as owner of the house. Lena continued her profession as music teacher (piano) in this house. Evidently, Hazel had sold her house to Dixon, and Lena had sold her 213 Wesley Street house, now owned by one Herman W. Cowan. Lena had then hired the 209 E. Wesley house from Dixon and had Hazel B. as roomer.

In 1945, Lena still lived at 209 Wesley, now with a new resident, Mrs Etta Simms.<sup>23</sup> She was staying at this address in 1946, 1947 and 1949 without residents.<sup>24</sup> The house on 315 Franklin had Janice (or Janie) Simpson as householder up to at least 1949.<sup>25</sup>

So there are no traces of Hazel B. Ladnier after 1943 and she seems to have disappeared in 1944. It is not known if she relocated to another place and when she died.

---

<sup>21</sup> Mezzrow, Mezz; Wolfe, Bernard, *Really the Blues*, Random House, New York, 1946.

<sup>22</sup> Polk's Jackson City Directory 1943; p. 220.

<sup>23</sup> Polk's Jackson City Directory 1945; p. 267 and p. 498

<sup>24</sup> Polk's Jackson City Directory 1946 and 1947.

<sup>25</sup> Polk's Jackson City Directory 1949; p. 365.